

THIS DRAWING IS UNPUBLISHED. RELEASED FOR PUBLICATION .19
 © COPYRIGHT 19 BY AMP INCORPORATED. ALL INTERNATIONAL RIGHTS RESERVED.

LOC	DIST	P	F	ZONE	LTR	REVISIONS	DATE	APPD
G	14			A		RELEASED PER 0720-0008-93	2-2-93	1 st DAP

METRIC
 DIMENSIONS LISTED IN mm [INCHES]

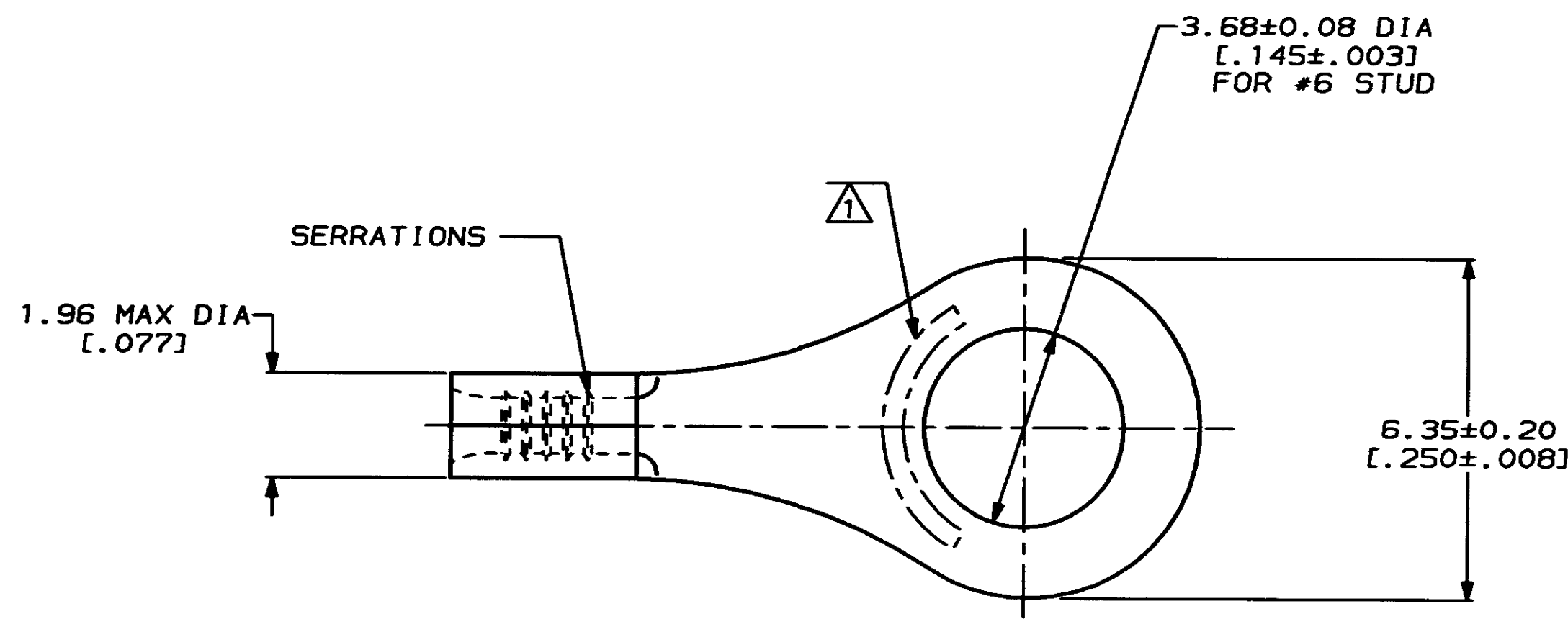

AMP WIRE RANGE	E13288 Listed
26-22 AWG STRANDED	NOT LISTED
LR7189 Certified	MILITARY P/N AND CLASS
NOT CERTIFIED	NOT APPLICABLE

△ STAMP AMP APPROX AS SHOWN

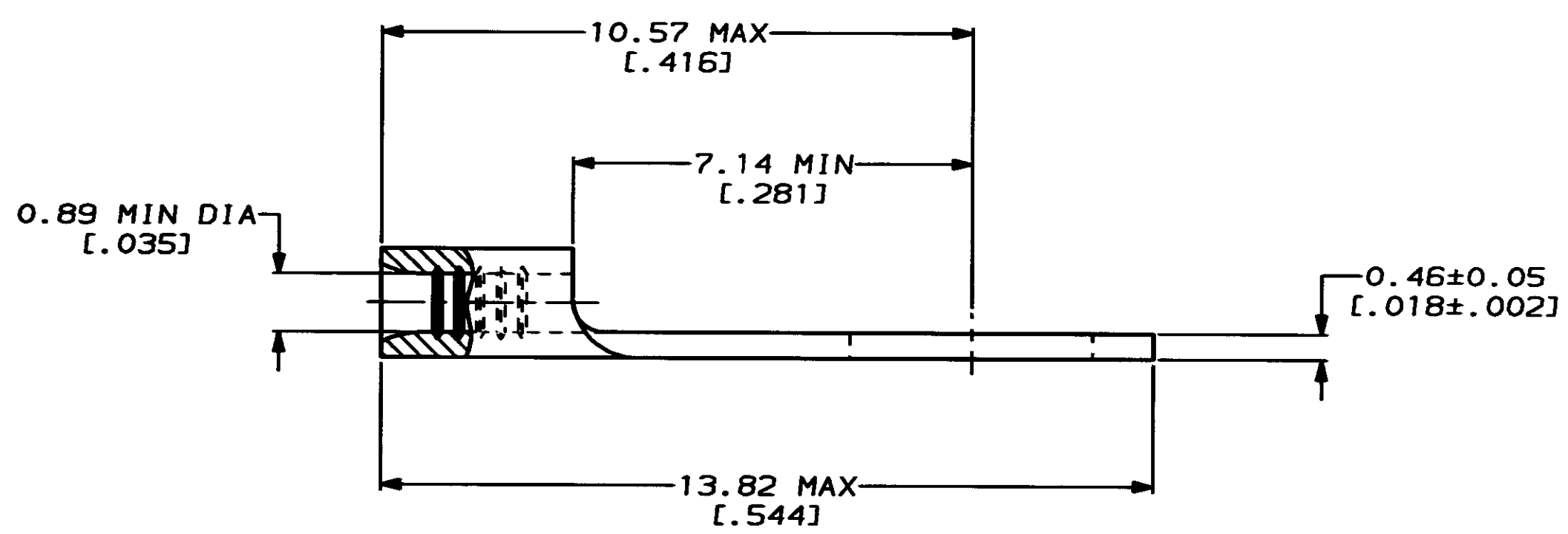

32858
 PART NO

AMP INCORPORATED
CUSTOMER SERVICE SYSTEMS

FOR ADDITIONAL PRODUCT INFORMATION OR COPIES OF DRAWINGS AND TECHNICAL DOCUMENTS	PRODUCT INFORMATION CENTER 1-800-522-6752
FOR APPLICATION TOOLING INFORMATION	TOOLING ASSISTANCE CENTER 1-800-722-1111
FOR ORDER ENTRY	1-800-526-5142

MAX RECOMMENDED OPERATING
 TEMPERATURE:
 170°C MAX

VOLTAGE RATING:
 NOT APPLICABLE

WIRE CROSS SECTIONAL AREA RANGE:
 0.1-0.41mm² [202-810] CIR MILS
 STRANDED

THIS DRAWING IS A CONTROLLED DOCUMENT FOR
 AMP INCORPORATED. IT IS SUBJECT TO CHANGE
 AND THE CONTROLLING ENGINEERING ORGANIZATION
 SHOULD BE CONTACTED FOR THE LATEST REVISION.

DO NOT SCALE PRINT.
 UNLESS SPECIFIED
 DIMENSIONS IN mm [INCHES]
 TOLERANCES ON:
 2 PLC DEC ± -
 3 PLC DEC ± -
 ANGLES ± -

MATERIAL
 COPPER PER
 ASTM B-152
 ANNEALED

FINISH
 TIN PLATE
 0.00254 [.000100] MIN
 THK PER MIL-T-10727

DR 2-2-93
 TA BRINKMAN

CHK 2-2-93
 DA PATTERSON

APPD 2-2-93
 DE MILLER

APPD 2-2-93
 JL HECKLEY

PRODUCT SPEC
 -

APPLICATION SPEC
 -

WEIGHT
 -

AMP AMP Incorporated
 Harrisburg, PA 17105-3608

NAME
**TERMINAL, RING
 TONGUE, BUDGET**

SIZE CAGE CODE 00779 DRAWING NO -32858

SCALE 10:1 SHEET 1 OF 1